





**INSTRUCTIONS
D'INSTALLATION**

NUMÉRO DE PIÈCE : F541SVC000

DESCRIPTION : DÉFLECTEUR D'AIR DE TOIT OUVRANT

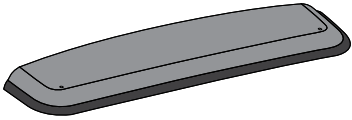
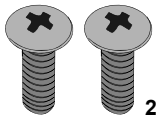
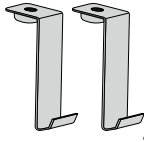
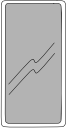
DESCRIPTION DU VÉHICULE : SUBARU WRX/STI

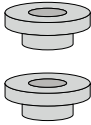
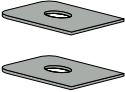
A  1x	B  2x	C  2x	D  2x
E  1x	F  2x	G  2x	

Outils requis

tournevis Phillips

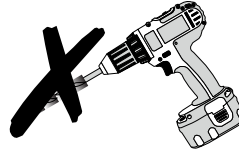

AUCUN OUTIL ÉLECTRIQUE

Signification des symboles :

 : Enlever

 : Poser

 : Déconnecter

 : Connecter

 : Emplacement des attaches ou vis

T : Couple de serrage

 : Desserrer

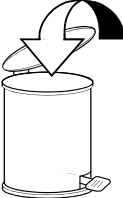
 : Jeter

 : Réutiliser

REMARQUES IMPORTANTES

- N'UTILISEZ PAS DE NETTOYANT À SOLVANT SUR LE DÉFLECTEUR D'AIR DU TOIT OUVRANT.
- N'UTILISEZ PAS DE FREIN FILETS (LOCTITE) SUR LES VIS DU DÉFLECTEUR D'AIR.
- UTILISEZ UNIQUEMENT DU SAVON ET DE L'EAU POUR NETTOYER LE DÉFLECTEUR D'AIR.

Le déflecteur d'air est conçu pour réduire le bruit de vent quand le toit ouvrant est en position ouverte. Toutefois, dans certains cas, le bruit peut être un peu plus fort si le toit est ouvert en inclinaison ou s'il est fermé.

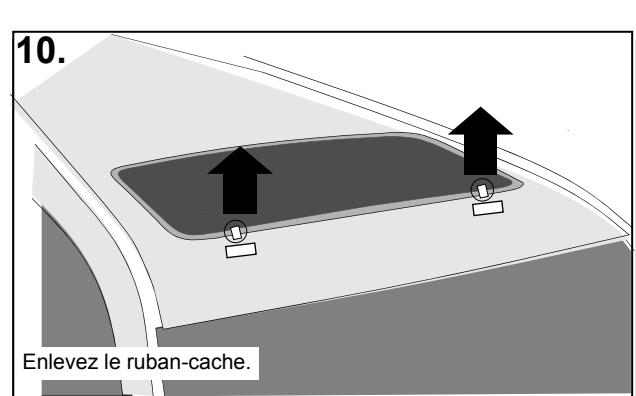
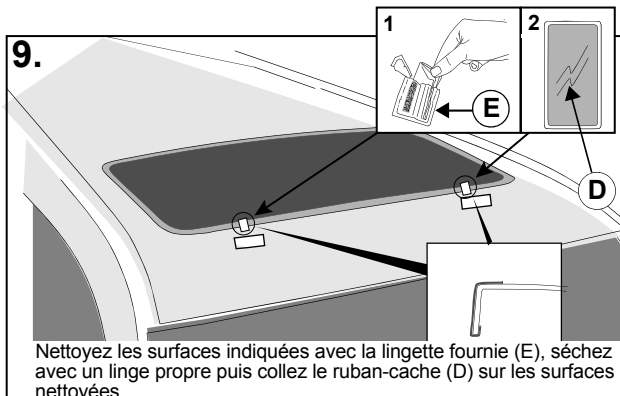
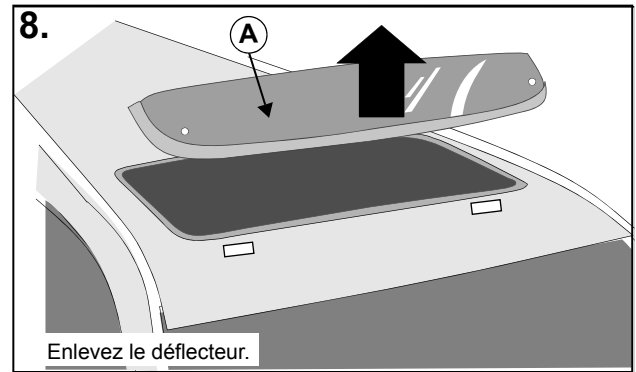
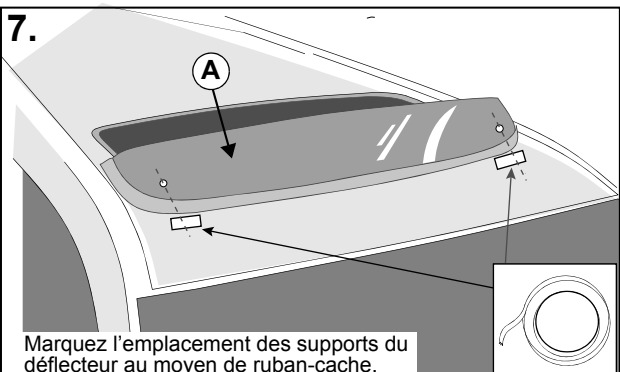
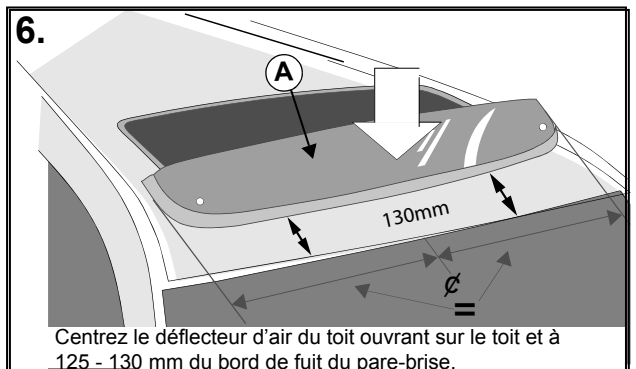
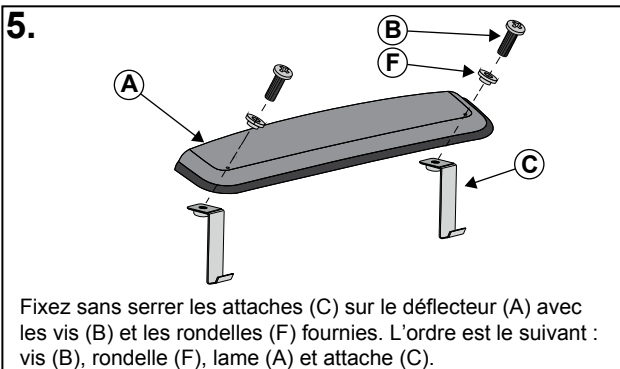
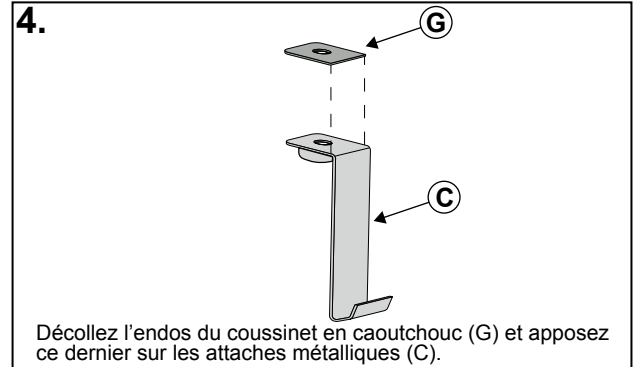
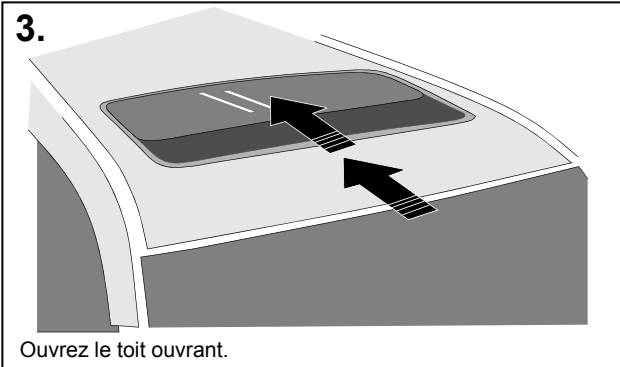
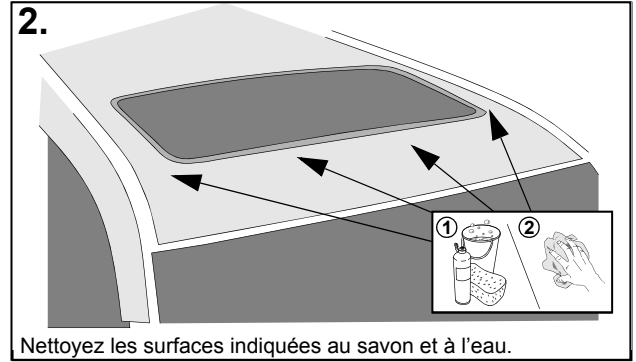
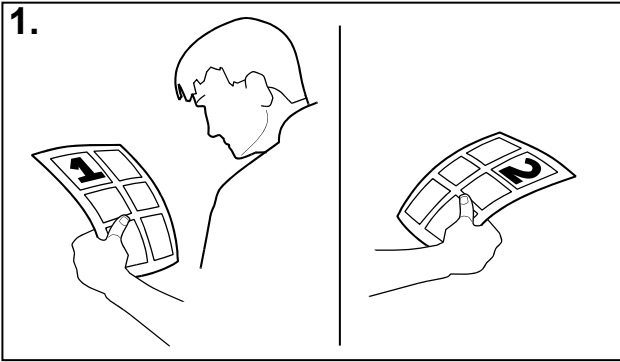

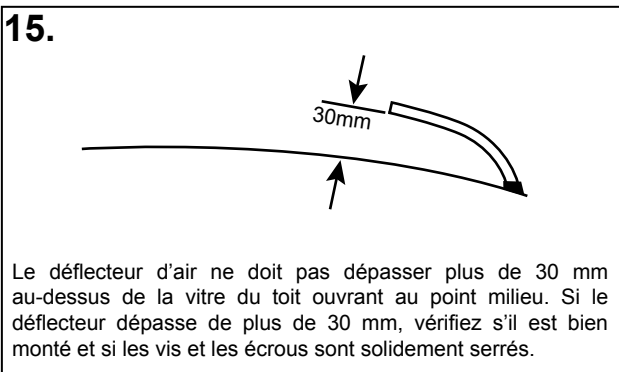
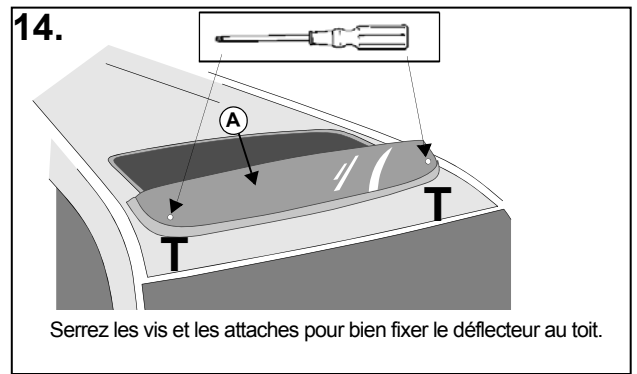
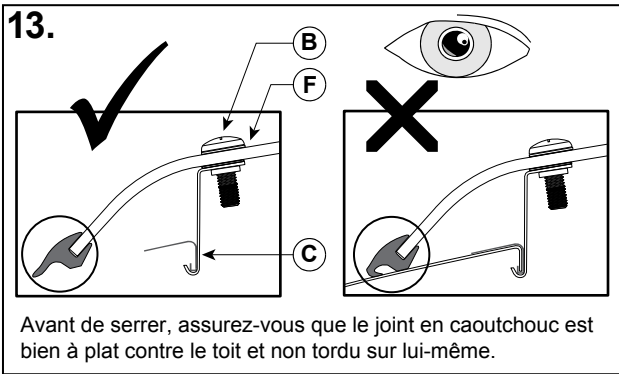
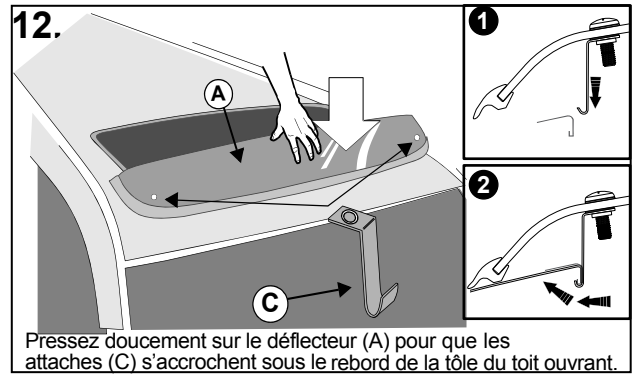
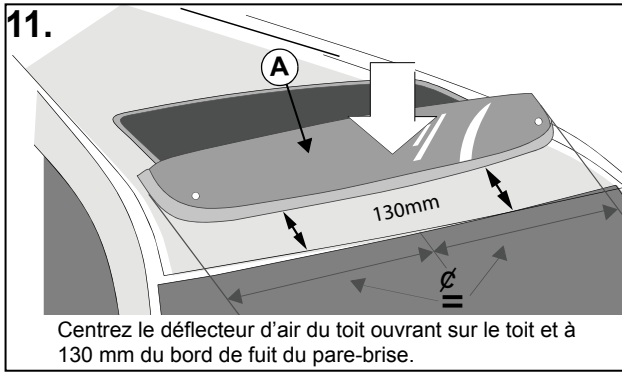

N'UTILISEZ PAS de nettoyant à solvant sur le déflecteur d'air du toit ouvrant.
UTILISEZ uniquement du savon et de l'eau pour nettoyer le déflecteur d'air.

