



OUTBACK | 2009



Innovation you can feel. Engineering you can trust.

With each passing year, the legend grows. More people join the Subaru faithful. And more drivers discover that the name Subaru is synonymous with the spirit of innovation and an unwavering commitment to excellence. This approach has led to the creation of a line of vehicles that delivers an absolutely uncompromising driving experience – one that blends together high levels of performance, safety, versatility, environmental friendliness and sheer fun. All in perfect balance.



Outback PZEV Plus





Outback 3.0R Premier
(shown with accessory kayak stacker)



WHY OUTBACK?

It's a purebred crossover.

The days of the vehicle that promises the world but delivers little are over – full stop. In its place, consider the 2009 Subaru Outback: a genuine crossover that offers rugged versatility, interior refinement and car-like driving dynamics. Powered by an engaging, fuel efficient and clean-burning SUBARU BOXER engine, the Outback also weighs in with Subaru symmetrical full-time All-Wheel Drive (AWD), a fully-independent long-travel suspension system, and award-winning active and passive safety features. Designed, engineered and built to be a true alternative to pseudo-crossovers, the Outback is ready for all kinds of adventure.

Outback 2.5i Limited Package



MODEL RANGE

A great getaway vehicle.

The Subaru Outback 2.5i is built for the weekend getaway. Sporting a 2.5L 4-cylinder SUBARU BOXER engine (170 horsepower, 170 lb-ft of torque) and the confidence-inspiring Subaru symmetrical full-time AWD, this versatile crossover is a fun and fuel efficient way to go... anywhere. The 2.5i is extremely well equipped right out the gate, with desirable features like standard heated front seats, 16-inch alloy wheels and SIRIUS® Satellite Radio. An upgrade Limited Package adds luxurious leather, dark tinted privacy glass and a twin-panel moonroof. The Outback PZEV Plus is also packed with a wealth of sought-after features and boasts advanced eco-friendly technology that reduces smog-forming emissions to virtually zero without any compromise in performance, convenience or value. Outstanding.

Main: Outback PZEV Plus



The Subaru Outback PZEV (Partial Zero Emission Vehicle) Plus meets California's Super Ultra Low Emissions Vehicle (SULEV) tailpipe standard and it achieves zero evaporative emissions. This combination makes it one of the cleanest gas-powered vehicles on the planet and a strong combatant in the fight against smog. Plus the Subaru Outback PZEV Plus is SmartWay™ certified by the U.S. Environmental Protection Agency, meaning it achieves strict, predetermined levels for fuel economy and tailpipe emissions.

MODEL RANGE

Even more of a great thing.

Featuring a 245-horsepower, 3.0L 6-cylinder SUBARU BOXER, the Subaru Outback 3.0R Premier is the choice for drivers who appreciate their rugged versatility with more than a touch of mechanical refinement. The smooth performance of this crossover is further aided by the standard SI-DRIVE engine management system and 5-speed Electronic Direct Control Automatic Transmission with SPORTSHIFT™. From a comfort and convenience standpoint, the 3.0R Premier offers a full suite of desirable amenities including a phenomenal Harman Kardon sound system and a GPS DVD-based navigation system. The Subaru Outback 3.0R Premier: the Outback for those who want a little more out of life.

Main: Outback 3.0R Premier
Left: Heated front seats
Middle: Power adjustable, foldable door mirrors with LED turn signals
Right: Steering wheel integrated audio controls





THE CABIN

A welcome surprise.

The 2009 Subaru Outback is a study in contrasts: Tough as nails on the outside, refreshingly refined on the inside. The cabin is filled with desirable features and high-grade materials designed to transport you and your passengers in comfort and style. The sweeping, wing-shaped dashboard is enhanced with titanium-style or woodgrain trim, creating a high-tech and regal effect. The seats, covered in either premium fabric or luxurious leather, are designed to provide support and reduce fatigue on those long road trips. The interior boasts comfortable seating for five adults and up to 2768L of useable space. To complete the picture: standard heated front seats, an available twin-panel moonroof and a surprisingly quiet ride. (Compromise is so five minutes ago.)

Main: Outback 3.0R Premier.
Top: Twin-panel moonroof
Bottom: Power adjustable seating



VERSATILITY

In tune with life.

Make no mistake: Despite its sporty dimensions, the Subaru Outback is a genuine, honest-to-goodness crossover and the perfect addition to an active lifestyle. Boasting a surprising amount of cargo space (more than many crossovers or SUVs), excellent towing capabilities (up to 1360 kg when properly equipped) and standard roof rails, the Outback has that go-anywhere/take-anything flexibility that others promise but fail to deliver on.



Outback 3.0R Premier shown with accessory trailer hitch.



Seating configuration

Comfort and convenience are the name of the game here. The cabin boasts comfortable seating for five adults and 60/40-split flat-folding rear seats that open up more space for storage. The driver's seat features 8-way power adjustability. And the entire passenger compartment is a model of efficient spatial design.

Luggage area



The Subaru Outback puts the "go" in cargo. Storage space balloons from the standard 847L (big enough for four tour-size golf bags or four full-size suitcases) to 1851L when the rear seats are folded down. For even more convenience and versatility, the Outback comes standard with roof rails that can be equipped to hold bicycles, kayaks, skis or an extra storage container.

All-round storage



Overhead compartment (2.5i model only)



Front console cup holders



Centre console storage with 12-volt outlet and auxiliary audio input



Front door pockets



Rear cup holders (in centre console)

ENTERTAINMENT

The wish list.

No need for regrets or remorse, looking back or thinking twice. With a long list of desirable amenities and options, the Subaru Outback sends a clear message: If you can imagine it, you can have it... even when you're in the middle of nowhere on some grand adventure.



GPS navigation

With the available DVD-based GPS navigation system*, getting lost on the weekends has never been more fun. This system offers a large, clear 7-inch screen and step-by-step instructions to help you find your way home again.

**Standard on 3.0R Premier*



Audio systems

Every Subaru Outback comes standard with an outstanding audio system. The available premium audio system* boasts a 6CD changer, MP3 compatibility, an auxiliary audio jack and a top of the line speaker package.

** Standard on 2.5i Limited Package and 3.0R Premier*



SIRIUS® Satellite Radio

All Subaru Outbacks also come standard with SIRIUS® Satellite Radio equipment pre-installed. This subscription service delivers 100% commercial-free music and radio programming and is offered to you *free of charge for the first three months!*



Harman Kardon

The incredible 440-watt speaker package available on most models includes no fewer than 9 Harman Kardon speakers (4 speakers, 4 tweeters and a subwoofer), plus an 8-channel amplifier with Digital Signal Processing (DSP). This premium speaker company is famous for transforming vehicles into rolling concert halls.

The nucleus of driving pleasure.

At Subaru, we are fuelled by a passion for excellence and obsessed with giving drivers an experience behind the wheel that blends superior reliability, stellar safety and sheer excitement. This fevered approach led us to the FIA World Rally Championship, the proving ground upon which we honed the SUBARU BOXER engine, Subaru symmetrical full-time AWD and our remarkable 4-wheel long-travel independent suspension system – a dynamic combination of technologies that produces unsurpassed confidence behind the wheel.

From the snow-covered roads of Sweden to the crippling heat of Greece, we learned our lessons well and transferred this knowledge into passenger vehicles with superior levels of agility, stability and traction. To this day, we continue to compete with two clear objectives in mind: Winning championships and bringing further advancements to each and every Subaru vehicle. These advancements are what help to make a Subaru, a Subaru – one of the safest, toughest and most enjoyable vehicles on the road.



SYMMETRICAL AWD

At Subaru, we have been building all-wheel drive vehicles since 1972. Currently, our entire vehicle lineup enjoys the benefits of this advanced approach to vehicle dynamics. The result of such foresight and commitment? The development and perfection of Subaru symmetrical full-time AWD. In this layout, all drivetrain components – the engine, transmission, driveshaft, and front and rear differentials – are logically aligned close to the centre point of the vehicle. This gives every Subaru vehicle heightened stability and excellent weight distribution, front to rear and side to side. This unique system is a

bilaterally balanced, simple design that provides exceptionally efficient power delivery and a lower centre of gravity compared to other systems. Engineered to be an AWD vehicle from the start allows for the symmetrical design of the drivetrain and the ability to deliver greater grip and quicker response to changing conditions. In addition, if any wheel senses slippage, the torque distribution between the front and rear is controlled automatically. Conclusion: Permanent reassurance that you are driving a crossover famed for its inherent balance, stability and control in a variety of driving conditions.



SUBARU BOXER

In the fight to become the best vehicle in your class, it helps to have a boxer in your corner – particularly a SUBARU BOXER. This horizontally-opposed engine layout is renowned for its smoothness: The left bank of pistons counteracts the firing motion of the right bank, thereby balancing each other out and reducing engine vibration overall. This smooth operator

also sits low in the engine compartment, giving each Subaru vehicle a remarkably low centre of gravity. To further enhance durability, handling and directional stability, every SUBARU BOXER is constructed of lightweight, high-strength aluminum. Net result: A powerful and balanced feel at all speeds and a level of performance other vehicles struggle to match.

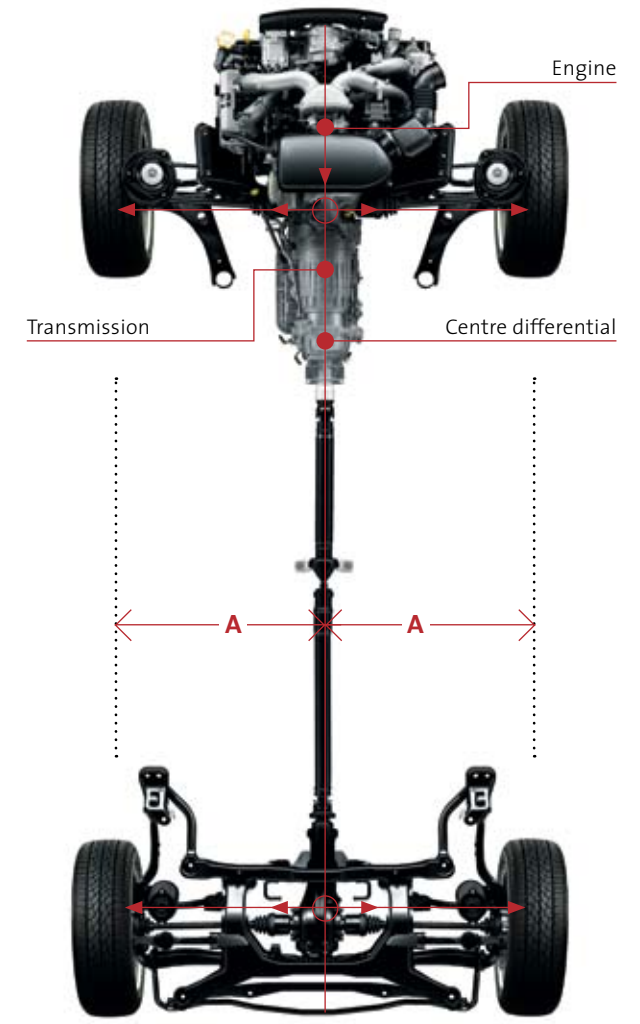

Three distinct advantages

Lower centre of gravity

The Subaru Outback is built from the ground up to have an extremely low centre of gravity, the cornerstone of this design being the SUBARU BOXER engine, placed low in the chassis. This layout, in turn, leads to reduced body roll, along with improved handling and stability, without the need for an overly stiff suspension.

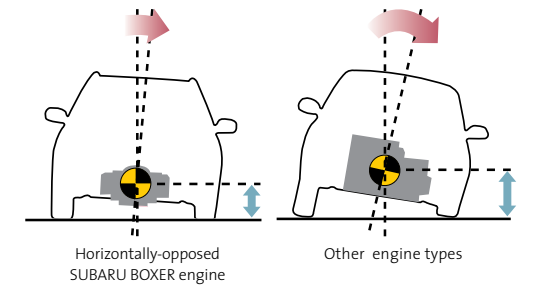

Reduced vibration

With its 180-degree, horizontally-opposed configuration, the SUBARU BOXER engine design cuts vibration dramatically by eliminating the inertia of opposing pistons as found in V-shaped or in-line engine configurations. The result of this innovative engine design is instant responsiveness throughout the rev range, unprecedented smoothness and greatly improved vehicle stability. In addition, less engine vibration also gives rise to a more peaceful and relaxing passenger cabin.

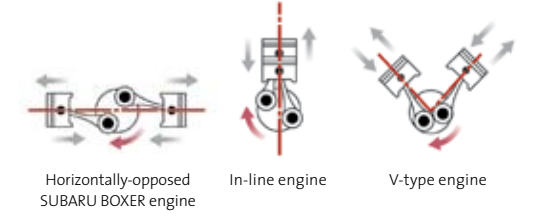

Increased grip

If your vehicle has four wheels, it makes sense that all four should play a role in keeping that vehicle planted on the road. But in front- and rear-wheel drive vehicles, two of the four wheels are essentially just passengers along for the ride. On the other hand, by transmitting power through all four wheels, vehicles equipped with Subaru symmetrical full-time AWD offer increased grip, stability, control and safety – regardless of road or weather conditions.

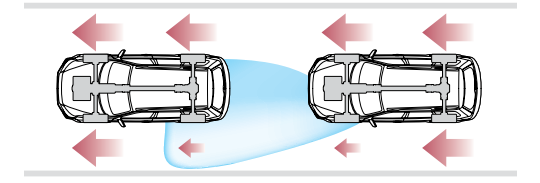

Diagrams for illustrative purposes.

The DNA of a champion

The apple does not fall far from the tree. In this case, the tree is the Subaru rally car – tested and perfected in the toughest form of motorsport known to man or machine, the FIA World Rally Championship. Since 1990, Subaru has become synonymous with championship-winning speed, handling and reliability. To this day, every Subaru vehicle incorporates the lessons learned on torturous rally stages to create a more thrilling, more reliable and all-around safer driving experience.





ENGINE

The motivating force.

The engines powering the 2009 Subaru Outback can best be described according to the setting in which they are found. They offer the performance of a sport wagon on the open road and the capability of an SUV on the back roads. The low positioning and torque delivery of the world-renowned SUBARU BOXER engine is especially suited to the Outback, giving this nimble crossover superb cornering characteristics and an all-around more stable feel. Next-generation engine technologies have further enhanced the driving experience, delivering both thrilling performance and remarkable efficiency.



rendering for illustrative purposes only.

SUBARU BOXER 2.5-litre SOHC

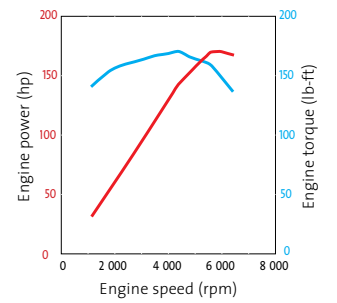

Output:
170 hp @ 6000 rpm;
170 lb/ft of torque @ 4400 rpm

The 2.5L 4-cylinder SUBARU BOXER may be smaller in size, but it's no less fun to drive. With the benefit of the technologically advanced i-Active Valve Lift System, superb low- and mid-range torque is produced – and so, too, is superior fuel efficiency. Sure and predictable power is generated throughout the rev range, making the Outback 2.5i or Outback PZEV Plus a sporty and efficient way to go. A proven design incorporating lightweight and superstrong aluminum alloy, this engine is also extremely reliable and durable.

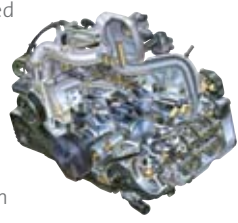

SUBARU BOXER 3.0-litre DOHC

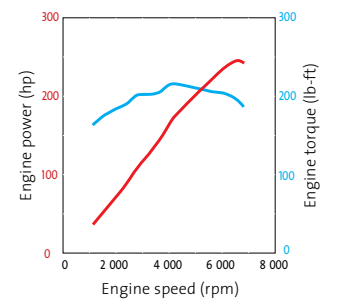

Output:
245 hp @ 6600 rpm;
215 lb/ft of torque @ 4200 rpm

The full force of Subaru engine technology plays out in the 3.0L 6-cylinder SUBARU BOXER engine found in the Subaru Outback 3.0R Premier. Its inherently smooth layout has been further enhanced by advanced engine technologies such as the Active Valve Control System and Active Valve Lift System. Net result: Smooth and linear power delivery, excellent low- and mid-range torque, reduced emissions and heightened fuel efficiency.



Advanced engine technologies

Subaru engines incorporate genuine green thinking to ensure maximum power and fuel efficiency under all operating conditions, combined with minimum emissions. The Subaru Active Valve Lift System and i-Active Valve Lift System employ a specially designed camshaft and two-piece valve lifters that work separately at low rpm and together at high rpm. The 3.0L engine powering the Subaru Outback 3.0R Premier features the Subaru Active Valve Control System (AVCS), which varies and optimizes the timing of the intake valves under idle, leisurely driving conditions or hard acceleration. These systems, precisely controlled by the engine management computer, create better low-end torque, engine efficiency and top-end power, while allowing the Outback to gain better fuel economy and meet strict emissions standards.

PZEV technologies

The Subaru Outback PZEV (Partial Zero Emission Vehicle) Plus delivers all the legendary Subaru qualities – safety, reliability, high performance, a high level of refinement and confidence-inspiring Subaru symmetrical full-time AWD – combined with unique features designed to fight smog-forming emissions.

The catalytic converter features a finer honeycomb mesh to more effectively convert exhaust gases by neutralizing them through a chemical reaction. A charcoal filter in line with the engine air filter absorbs fuel and oil vapors that normally escape into the atmosphere when a typical engine is turned off. Special fuel injectors also reduce evaporative emissions when the car is at rest. And the ignition timing is adjusted automatically on start-up to heat the catalytic converter more quickly and ensure the emissions controls are working at peak efficiency at all times.

As a result of all this technology, the PZEV is the cleanest-running gasoline-powered vehicle on the market today. It emits zero evaporative emissions and meets the Super Ultra Low Emissions Vehicle (SULEV) tailpipe standard, which is 90% cleaner than the average new automobile. The Subaru Outback PZEV Plus is also SmartWay™ certified by the U.S. Environmental Protection Agency for achieving strict, predetermined levels for fuel economy and tailpipe emissions. All this in a vehicle that doesn't cost any more for regular maintenance than a normal vehicle.



SI-DRIVE (SUBARU Intelligent Drive)

This highly-advanced engine management system offers the choice of three different drive modes, each with its own engine and transmission characteristics. By switching modes, the driver triggers changes to the engine mapping that then modify the electronic throttle control and transmission response.

Intelligent Mode (I) delivers heightened smoothness in low-traction conditions and boosts fuel economy by as much as 10%. **Sport Mode (S)** is for all-around use; it provides linear throttle response for everyday driving situations and extra engine power when needed. **Sport Sharp Mode (S#)** exploits the full potential of the SUBARU BOXER engine, delivering instant throttle response for maximum enjoyment.

SI-DRIVE is standard on the Subaru Outback 3.0R Premier.



TRANSMISSION

Your link to incredible performance.

A powerful engine and a superbly engineered all-wheel drive system are just the start to achieving superior performance. Another factor plays a critical role: a transmission with the ability to deliver power to all four wheels simultaneously, regardless of road or traction conditions. Subaru's transmissions are uniquely designed to work in conjunction with Subaru symmetrical full-time AWD in order to create greater traction, control and driver confidence.



5-speed Manual Transmission (SMT)

Manual transmission

The 5-speed manual transmission – in combination with Subaru symmetrical full-time AWD and the viscous coupling limited-slip centre differential – provides certain power delivery and sure-footed grip under all conditions. This design maintains a 50/50 (front/rear) torque split distribution, giving the Outback maximum traction and a distinctly sporty edge over the competition.



▲ 4-speed Electronic Direct Control Automatic Transmission with SPORTSHIFT™ (4EAT SS)

◆ 5-speed Electronic Direct Control Automatic Transmission with SPORTSHIFT™ (5EAT SS)

Automatic transmissions

The Subaru Outback is available with two types of automatic transmissions: the 4-speed Electronic Direct Control Automatic Transmission with SPORTSHIFT™ (for the 2.5i and PZEV Plus models) and the 5-speed Electronic Direct Control Automatic Transmission with SPORTSHIFT™ (for the 3.0R Premier). These transmissions feature advanced Electronic Throttle Control for smooth acceleration and precise gear changes that attune themselves to your driving style. The 4-speed incorporates a multi-plate transfer clutch, while the 5-speed uses a Variable Torque Distribution (VTD) centre differential. Both transmissions feature an active torque-split AWD design that responds to traction conditions, the gear selected and driver inputs by continuously controlling the torque distribution front to rear. The 5-speed is among the quickest-shifting transmissions around – 0.2 seconds from one gear to the next – and it also features automatic blipping control to match engine speeds on downshifts.



HANDLING

Pick a road, any road.

To fully realize the capability of the 2009 Subaru Outback, you need to get behind the wheel and find a challenging road – one with twists and turns, hills and valleys, uneven pavement and maybe even the occasional fallen tree. The Outback is as nimble as they come, the result of the rally-proven fully-independent long-travel suspension and Subaru symmetrical full-time AWD. This combination ensures that the wheels are always in contact with the road and are always generating forward momentum. Whether the path you choose is smooth as silk or rugged as a logging road, the Outback shines like a diamond.



rendering for illustrative purposes only.

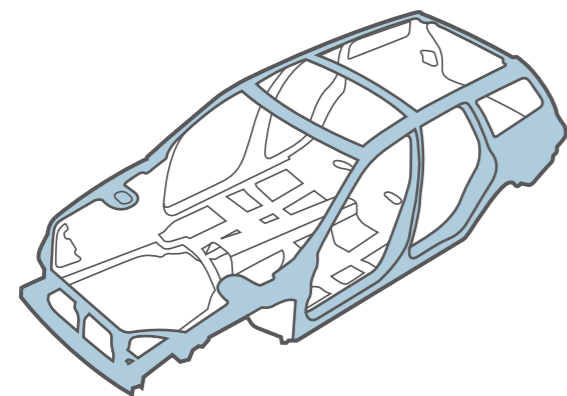

Lightweight components

To maximize the overall driveability provided by Subaru symmetrical full-time AWD, the body of the Subaru Outback has been kept light, utilizing a structure that eliminates the need for extra weight without compromising on strength or safety. Combined with a low centre of gravity drivetrain, this design gives the Outback unique advantages over other crossovers including superb cornering, remarkable agility and enhanced fuel efficiency.



Front suspension

The super-strong, rally-inspired front strut design has been honed to perfection on the Subaru Outback. Impressive rigidity and a wide tread provide greater stability when steering or cornering, while the anti-dive suspension geometry and stabilizer bar help deliver unparalleled performance overall. And with 213 mm (minimum) of ground clearance, the Outback will overcome most obstacles in the road with ease.

Rear suspension

The multi-link rear suspension system incorporates anti-squat suspension geometry and a stabilizer bar to create assured handling and roadholding over even the roughest surfaces. Developed from decades of world rally competition on the most punishing roads known to man or machine, this suspension is tough, reliable and capable to the core.

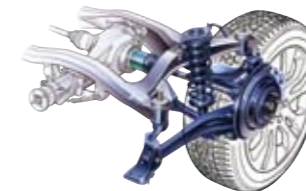

SAFETY

Your safety is our priority.

Some things should never be left to chance – especially the safety of you and your passengers. Every Subaru vehicle is designed to meet the very highest standards for crash worthiness. Active safety systems – such as Subaru symmetrical full-time AWD and the Vehicle Dynamics Control system – give the driver the tools needed to avoid an accident at all costs. In the event that an accident is unavoidable, passive safety features like Subaru’s advanced ring-shaped reinforcement frame provide much-needed layers of protection. Net results: top-notch crash-test ratings* across the board for the Subaru Outback and a more comforting driving experience for you.



rendering for illustrative purposes only.

Vehicle Dynamics Control system

Even when driving a vehicle with Subaru symmetrical full-time AWD, the laws of physics still apply and the level of grip can be exceeded. In these rare times, it’s comforting to know that the Vehicle Dynamics Control system† and Traction Control System are standing guard. These systems employ a network of sensors to detect when a loss of control is imminent, then make precise adjustments – altering AWD torque split (4EAT SS and 5EAT SS models), applying brake pressure to individual wheels and controlling engine power output – to restore vehicle stability.

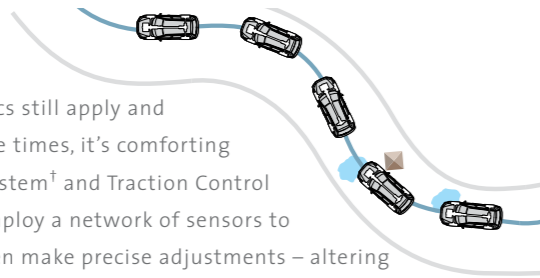

Brakes

An effective braking system is central to an effective active safety strategy – and the 2009 Subaru Outback puts this strategy into motion. Standard disc brakes on all four corners for increased stopping power. Standard 4-wheel/4-sensor/4-channel ABS to precisely control brake pressure. And standard Electronic Brake-force Distribution to shorten braking distances when carrying a heavy load.

† The Subaru Vehicle Dynamics Control system may also be known as Electronic Stability Control. Standard on Outback 2.5i Limited Package, PZEV Plus and 3.0R Premier

2009 Outback not yet tested.

*5-star front and side-impact ratings for 2008 Outback. U.S. Government star crash-test ratings are part of the National Highway Traffic Safety Administration’s (NHTSA’s) New Car Assessment Program (www.safercar.gov). A five-star crash-test rating is the highest government rating for a) Driver and right front seating positions in frontal crash tests and b) Front and rear seating positions in side-impact crash tests.

All-around visibility

Active safety begins with visibility. In other words, you can’t miss what you can’t see. With its optimal seating position, carefully designed side pillars and generous glass area, the Subaru Outback provides excellent visibility to the front, the sides and the rear of the vehicle.



Seatbelts, airbags, active head restraints and seat anchors

The Subaru Outback comes standard with a wealth of passive safety features designed to protect you and all your passengers in the event of an accident. Front seatbelts with pre-tensioners to hold you in place and load limiters to ease impact and guard against injury. Front, front-seat side-impact and side curtain airbags. Front-seat head restraints that automatically move forward in a rear-end collision to reduce shock to the head and neck. And the ISO-FIX/LATCH child seat anchor system with three-point seatbelts for the rear seats.

Advanced ring-shaped reinforcement frame

Subaru’s advanced ring-shaped reinforcement frame found in the Subaru Outback has generated superior crash-test ratings* and widespread praise. The essentials: a uniform, interconnected energy-absorbing safety cell comprised of the roof, door beams, side pillars and floor. This envelops the entire passenger cabin, thereby helping to dissipate impact energy from all directions. In the event of a severe frontal impact, this advanced design also sees the main frame compress gradually and the engine slide under the passenger compartment.



FEATURES

The 2009 Subaru Outback is the perfect alternative to the typical SUV, offering genuine go-anywhere capability without all the excess bulk. Rugged and refined throughout, the Outback is the ideal choice for when the going gets rough.



Not all features shown are standard on all models. See specifications for availability.



Roughing it can be fun – especially when it's not too inconvenient. While the Subaru Outback allows you to explore your wilder side, the interior ensures you never lose touch with your appreciation for comfort and convenience.

Not all features shown are standard on all models. See specifications for availability.



1 Heated door mirrors



2 Wiper de-icer



3 Multi-reflector halogen fog lights



4 Raised-profile roof rails and crossbars (lockable)



1 Cruise control (steering wheel integrated)



2 Automatic climate control (dual-zone)



3 Tilt/telescopic steering wheel



4 Electroluminescent gauges



5 Rear roof-line spoiler



6 Splash guards



7 Privacy tinted glass



8 17-inch alloy wheels (3.0R Premier shown)



5 Interior accents (dependent on interior colour)



6 Rear seat armrest



7 Map spotlights



8 Cargo area: Tray, cargo hooks, 12-volt power outlet and retractable cargo cover

LINEUP

Outback 2.5i

Horizontally-opposed, 4-cylinder, 2.5L SUBARU BOXER engine with i-Active Valve Lift System
170 horsepower and 170 lb-ft of torque
5-speed Manual Transmission (5MT) or optional 4-speed Electronic Direct Control Automatic Transmission with SPORTSHIFT™ (4EAT 5S)
Subaru symmetrical full-time All-Wheel Drive
Anti-lock Braking System, Electronic Brake-force Distribution (EBD)
Driver and front passenger front and side-impact airbags; side curtain airbags
16" aluminum alloy wheels; splash guards
Raised-profile roof rails
Multi-reflector halogen fog lights
Heated front seats; power adjustable driver's seat with lumbar support
AM/FM/CD/MP3/WMA audio system with 6 speakers and auxiliary audio input
SIRIUS® Satellite Radio (3-month trial subscription included)
Air conditioning with air filtration
Premium cloth upholstery



Exterior colours available: Deep Bronze Metallic, Obsidian Black Pearl, Quartz Silver Metallic (shown), Satin White Pearl. With Quartz Silver Metallic cladding: Diamond Grey Metallic, Newport Blue Pearl. Interior colour: Charcoal Black (shown) or Taupe dependent on exterior colour.

Limited Package

Available for Outback 2.5i (4EAT 5S) only:
Limited-slip viscous-type rear differential
Vehicle Dynamics Control system and Traction Control System (TCS)
17" aluminum alloy wheels
Power tilting and sliding twin-panel glass moonroof
Privacy tinted glass
Power adjustable, foldable, heated, body colour door mirrors
Lockable crossbars; body colour door handles
Additional audio features: 6CD premium audio system
440-watt Harman Kardon 9-speaker system with 8-channel Harman Kardon amplifier
Leather seat inserts; leather-wrapped controls with woodgrain trim
Air conditioning with automatic dual-zone climate control and air filtration
Retractable cargo cover and cargo area tray
Windshield wiper de-icer; dark upper sunshade



Exterior colours available: Deep Bronze Metallic, Harvest Gold Metallic, Obsidian Black Pearl, Quartz Silver Metallic, Satin White Pearl. With Quartz Silver Metallic cladding: Diamond Grey Metallic (shown). Interior colour: Charcoal Black (shown) or Taupe dependent on exterior colour.

Outback PZEV Plus



Includes all standard Outback 2.5i features as well as:
PZEV equipment
Limited-slip viscous-type rear differential
Vehicle Dynamics Control system and Traction Control System (TCS)
Power adjustable, foldable, heated, body colour door mirrors with LED turn signals
Power tilting and sliding twin-panel glass moonroof
Body colour door handles
Privacy tinted glass
Lockable crossbars; rear PZEV badging
440-watt Harman Kardon 9-speaker system with 8-channel Harman Kardon amplifier
Leather-wrapped steering wheel
Retractable cargo cover and cargo area tray



Exterior colours available: Deep Bronze Metallic, Obsidian Black Pearl, Quartz Silver Metallic, Satin White Pearl, Seacrest Green Metallic (shown). With Quartz Silver Metallic cladding: Diamond Grey Metallic, Newport Blue Pearl. Interior colour: Charcoal Black (shown) or Taupe dependent on exterior colour.

Outback 3.0R Premier

Horizontally-opposed, 6-cylinder, 3.0L SUBARU BOXER engine with Active Valve Lift System, Active Valve Control System and SI-DRIVE
245 horsepower and 215 lb-ft of torque
5-speed Electronic Direct Control Automatic Transmission with SPORTSHIFT™ (5EAT 5S)
Limited-slip viscous-type rear differential
Vehicle Dynamics Control system and Traction Control System (TCS)
Power adjustable, foldable, heated, body colour door mirrors with LED turn signals
Power tilting and sliding twin-panel glass moonroof
17" aluminum alloy wheels
Additional audio features: 6CD premium audio system
440-watt Harman Kardon 9-speaker system with 8-channel Harman Kardon amplifier
GPS DVD-based navigation system and monitor system with touch-screen display
Retractable cargo cover and cargo area tray
Leather seat inserts; leather-wrapped controls with woodgrain trim



Exterior colours available: Deep Bronze Metallic (shown), Harvest Gold Metallic, Obsidian Black Pearl, Quartz Silver Metallic, Satin White Pearl. With Quartz Silver Metallic cladding: Diamond Grey Metallic. Interior colour: Charcoal Black or Taupe (shown) dependent on exterior colour.

ACCESSORIES

Rest assured, the 2009 Subaru Outback is built for all kinds of adventure right out of the box. But a variety of genuine Subaru accessories can bring added comfort, convenience and utility to every weekend getaway. Whether your passion is for camping or kayaking, gardening or hiking, skiing or biking – these accessories will ensure your Outback is primed and ready for anything.

- Armrest extension
- Battery warmer
- Bike carriers (trailer hitch mounted and roof mounted)
- Block heater
- Cargo area nets (rear, side, seatback)
- Cargo area spotlight
- Cargo area tray
- Cargo area cover (retractable)
- Compartment divider (dog guard)
- Crossbar set
- Front end cover (full and half)
- Hood deflector
- Kayak stacker
- Rearview mirror - auto-dim with compass and HomeLink®
- Remote engine starter kit (AT only)
- Roof cargo bin (several styles and sizes)
- Rubber floor mats
- Security system upgrade - shock sensor
- Ski/snowboard carrier
- Subwoofer/amplifier
- Trailer hitch assembly
- Underguard (front)
- Wheel lock set

Visit www.subaru.ca or your local Dealer for more accessory options.



Outback 2.5i shown with crossbars, kayak stacker, compartment divider and cargo tray.



Ski/snowboard carrier



Hitch mount bike carrier



Roof cargo bin
(several styles and sizes available)



Hood deflector



Compartment divider (dog guard)



Subwoofer

OWNER BENEFITS



Subaru Warranties

Every Subaru vehicle is designed and built to offer our customers the highest possible level of quality and reliability. We are proud of our vehicles and proud to stand behind them with a comprehensive warranty. For 2009 model year vehicles, the warranty on all Subaru vehicles consists of:

New Vehicle Limited Warranty (36 month/60,000 km) – Covers basic and major components for 36 months or 60,000 km.

Major Component Limited Warranty (60 month/100,000 km) – Extends coverage of major components (more than just powertrain) up to 60 months or 100,000 km.

Surface Corrosion Limited Warranty (36 month/60,000 km) – Covers surface corrosion to visible painted body panels for 36 months or 60,000 km.

Anti-Perforation Limited Warranty (60 month/unlimited km) – Covers perforation due to corrosion to body sheet metal panels for 60 months, regardless of kilometres.

Emission Control System Limited Warranty – Covers the majority of emissions components for 36 months or 60,000 km and the major parts of the emission control system for 96 months or 130,000 km.

Parts and Accessories Limited Warranty – Covers Subaru parts and accessories installed by the Dealer prior to retail delivery of the vehicle for 36 months or 60,000 km, and Subaru parts and accessories installed by the Dealer after the retail delivery of the vehicle for 12 months or 20,000 km from the date of the installation.

The above information is an overview of warranty coverage and is not a warranty statement. If you wish to see more details regarding Subaru warranties, please refer to your Subaru warranty booklet, contact your local Dealer or visit our Web site at subaru.ca.

Subaru C.A.R.E. (Customer Assistance for Roadside Emergencies)

The SUBARU C.A.R.E. program – which is backed by the Canadian Automobile Association (CAA) – is offered free of charge for the first three years from date of purchase on every new Subaru vehicle or as part of a Subaru Protection Plan. As a SUBARU C.A.R.E. member, you can count on fast, courteous emergency roadside assistance 24 hours a day, 365 days a year. You will receive a membership card and have access to a dedicated toll-free telephone number (in English or French), allowing you to take advantage of over 20,000 roadside assistance contractors and 1,000 CAA and American Automobile Association (AAA) offices throughout Canada and the United States. Ask your Dealer for details or visit subaru.ca.

Subaru Canada, Inc. is proud to be the first vehicle manufacturer to have a direct relationship with CAA, giving our customers the benefit of CAA's unparalleled level of experience and service.

Subaru Protection Plan

As a Subaru owner, you have expectations for a pleasurable, trouble-free ownership experience – now and into the future. Once your 36 month/60,000 km New Vehicle Limited Warranty period ends,* our Subaru Protection Plan can prolong your hassle-free ownership experience with 3 levels of extended service contract coverage tailored to your needs: Powertrain Protection; Major Protection; or Complete Protection (best level of coverage to complement the 60 month/100,000 km Major Component Limited Warranty). This extended service contract offers comprehensive mechanical and electrical coverage and a number of additional features and benefits. Be sure to ask your Dealer for details or visit subaru.ca.

**If you already own a Subaru vehicle and it is still within the 36 month/60,000 km New Vehicle Limited Warranty period, you are still eligible.*



subaru.ca

The Supplemental Restraint System (SRS airbags) affords the driver and passenger additional protection in some collisions. This system provides supplemental protection only, and seatbelts must be worn in order to avoid injuries to out-of-position occupants upon airbag deployment. The combination of SRS and seatbelts provides the best protection in a serious accident. All illustrations, specifications, features and photographs contained in this brochure are based on product information available at the time of its printing, and may not be completely accurate following its publication. Colours shown may vary due to reproduction variations in the printing process, and some vehicle parts cannot be shown in certain photographs. Subaru Canada, Inc. reserves the right to discontinue or make changes at any time, without notice or incurring obligations, to colours, materials, equipment, accessories, features, specifications and models, or to change their prices. Some models shown may be from international markets and are not available in Canada, or they may be shown with equipment or accessories which are optional (at extra cost) or only available in certain combinations, or they may be subject to product delays or not be available in Canada. Please visit our Web site for the latest information and specifications. For complete details on product updates, warranties or the Subaru CARE program, please contact your Subaru Dealer. Outback, Subaru, SUBARU BOXER, Subaru CARE and Subaru CARE Customer Assistance for Roadside Emergencies are registered trademarks. harman/kardon and MMD are registered trademarks of Harman International Industries, Inc. HomeLink is a registered trademark of Johnson Controls, Inc. "SIRIUS" and the SIRIUS dog logo are trademarks of SIRIUS Satellite Radio Inc. SPORTSHIFT is a registered trademark of Prodrive Ltd. Printed in Canada. © 2008 Subaru Canada, Inc. 2009 model year.



Environmental Management System (EMS) ISO 14001:2004 certified by SGS
Brochure is printed on 100% chlorine-free bleached pulp (TCF), contains up to 30% pre-consumer recycled fibre and uses vegetable-based inks to be fully recyclable with no harmful residue.
www.subaru-earth.com



SBO09E